



Zgaird**X**

Zgaird

OIL INJECTION AIR COMPRESSOR

MITSUBISHI SEIKI

Z screw

a world-class compression mechanism

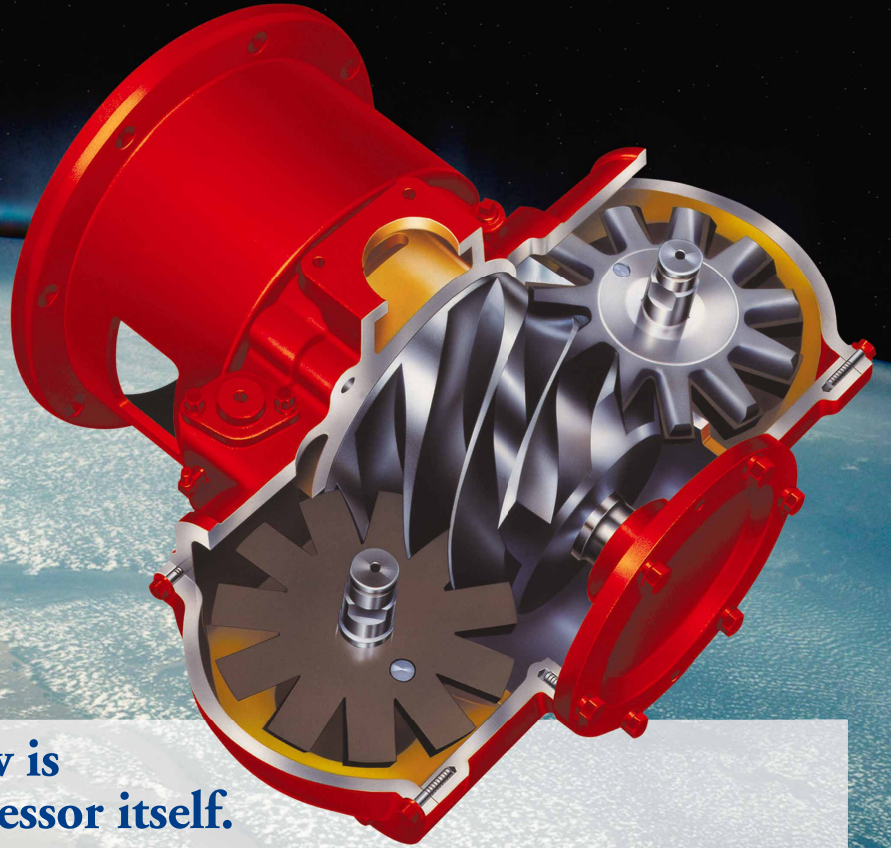

Evolution of Zscrew is evolution of compressor itself.

Z-series is indeed the origin of the product series of the Mitsui Air Compressor. Since launched the Z screw air compressor on 1972, we have constantly responded the needs of the times that change day by day to evolve it as a high efficient, energy saving air compressor. Then, we launched the inverter controlled ZV series that have been improved to deal with the ongoing environmental issues. Now we have lined up the lower noise and space saving advanced model (Zgaiard) mounting the brand-new IPM (permanent magnet) motor to meet users' expectation. Please note also that the Scroll air compressor series (Escal), that have been receiving good reputations since their launching on 1988, are now graded up to have the more high efficiency and energy saving capability. They are most appropriate for countering the environmental issues to be required by the Earth and Industries.

Compressors design

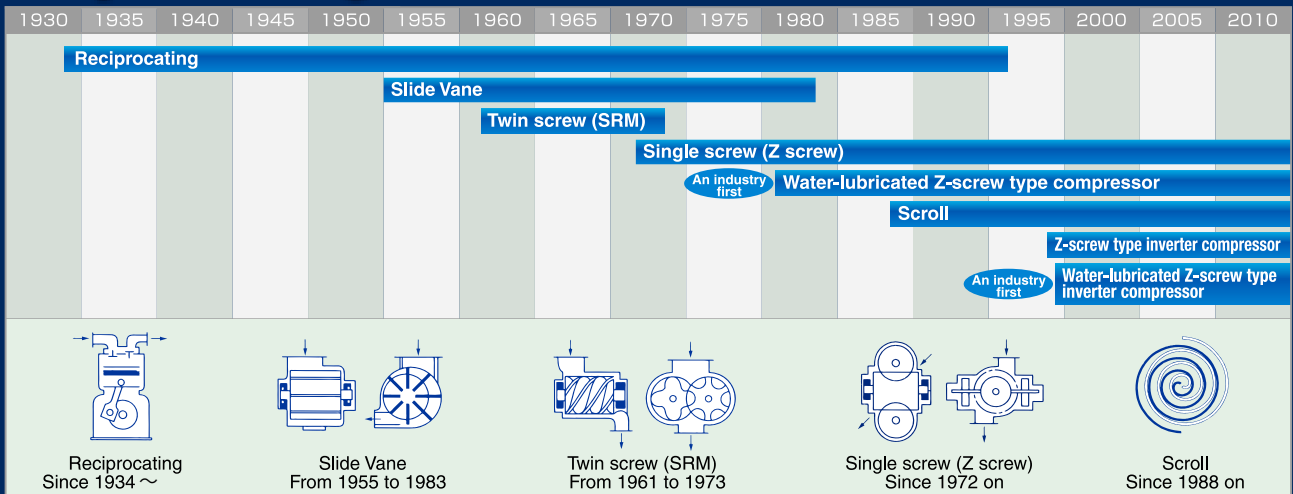

Simple construction and sealing effect realize excellent performance.

Primary factor of high efficiency and durability of "Z screw" is achieved by sealing gaps of each portion with oil in good balance by simple constitution consists of one screw rotor and two gate rotors. It holds noise and vibration in a minimum whereas efficiency does not deteriorate in low rotation either. "Z screw" of this superior mechanism. It extends the maintenance cycle marvelously and represents maximum capability in the inverter control.

Comparison of Z screw with Dry Twin screw

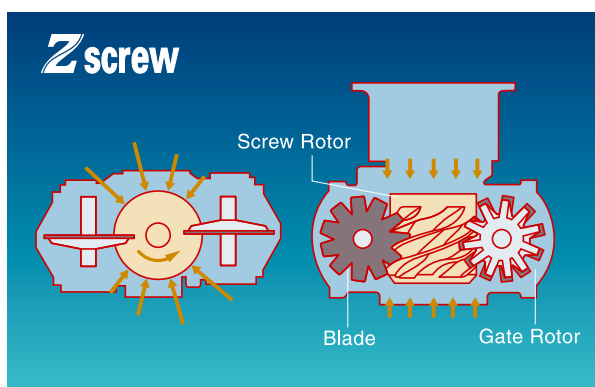

- Radial and axial loads eliminate each other, theoretically resulting a zero load

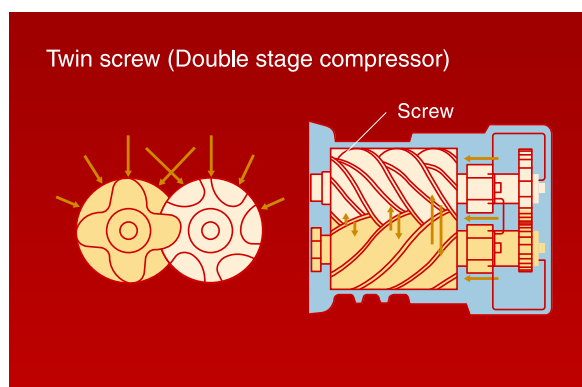

- Radial load and distance between the two screw axles place significant limitations on bearing load

Air flow

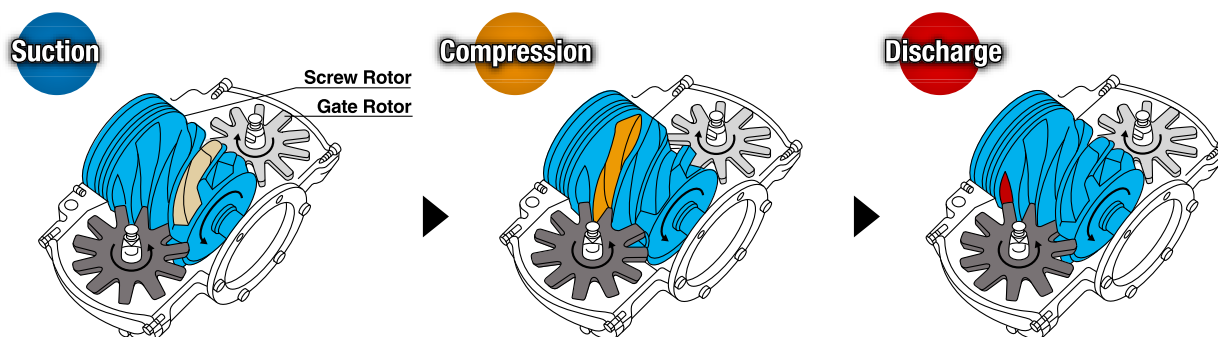

High reliability implemented by the precision

High precision technology of the MITSUI SEIKI, also known as a machine tool manufacturer, is utilized on processing the compression section to make up the Z screw air compression mechanism that realizes the high efficiency and high stability.



Gate Rotor



Screw Rotor



Blade



We offer a wide lineup of products to apply

MITSUI SEIKI OIL INJECTION TYPE SCREW COMPRESSOR SERIES

Ultimate high productive and energy saving achieved by the inverter control

Zgaiard X

Inverter Compressor

Air cooled 22 / 37kW
(option: water cooled 22 / 37kW)

- Inverter
- High temperature rigidity against global warming
- Z-mate compatible
- IPM motor
- Quick response start system
- Energy saving
- High efficiency
- Increasing
- IT touch panel
- Air cooled fan inverter
- Air Volume UP
- Red-CX compatible



Details ▶ 5,6

Zgaiard X

Inverter Compressor

Air cooled 55 / 75kW

Water cooled 55 / 75kW

- Inverter
- High temperature rigidity against global warming
- Z-mate compatible
- IPM motor
- Quick response start system
- Energy saving
- High efficiency
- Increasing
- IT touch panel
- Air cooled fan inverter
- Air Volume UP
- Red-CX compatible

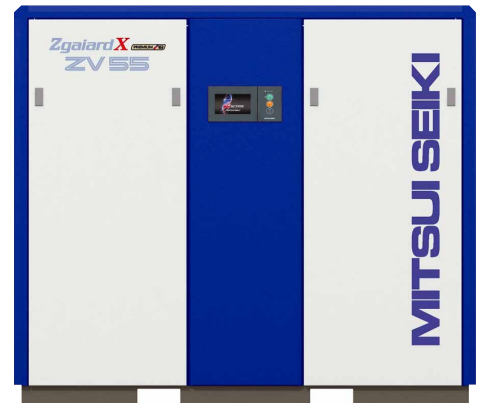

Details ▶ 7

Zgaiard

Inverter Compressor

Air / Watercooled 150kW

- Inverter
- Energy saving
- IPM motor
- High efficiency
- Red-CX compatible

Basic Compressor

Air / Watercooled 150kW

- IE3 motor
- High efficiency
- Red-CX compatible

Details ▶ 9



Advanced scroll type

ESCAL series

Air cooled 3.7 / 5.5kW

- IE3 motor
- High efficiency
- Compact



Details ▶ 10

for any needs, from compact to large units.

Basic type with simple design optimized for environmental performance

ZgaiardX

Basic Compressor

Air cooled 22 / 37kW
(option: water cooled 22 / 37kW)

IE3 motor

Environmentally friendly

High efficiency

Air Volume UP

Red-CX compatible



Details ▶ 5,6

ZgaiardX

Inverter Compressor

Air cooled 7.5~15kW

7.5kW / 11kW / 15kW

Inverter

Energy saving

Red-CX compatible

High efficiency

IE3 motor

Air Cooled fan inverter

Basic Compressor

Air cooled 7.5~15kW

7.5kW / 11kW / 15kW

IE3 motor

High efficiency

Red-CX compatible

Basic Compressor

Air cooled 55 / 75kW

IE3 motor

Red-CX compatible

Air Volume UP

High efficiency

Environmentally friendly

Zgaiard

Water cooled 55 / 75kW

IE3 motor

High efficiency

Red-CX compatible



Details ▶ 8

Energy saving machine

Plural control system

Red CX



Averaging operating time

Averaging the operating time of inverter machine

Alternate operation

Turn back control

Permanent fixed operation

2 patterns of pressure settings by weekly timer

Start and stop in fixed order



Receiver tank

Instantaneous consumption

Energy saving

Lengthen machine's lifetime

Stable pressure supply

Details ▶ 11,12

ZgaiardX series Inverter Compressor Basic Compressor

22/37kW

MITSUBISHI SEIKI OIL INJECTION TYPE SCREW COMPRESSOR SERIES

NEW COMPRESSOR MIGHTY WORRIOR ZgaiardX!

HIGH PERFORMANCE ▫ HIGH EFFICIENT ▫ MULTI FUNCTION

Zgaiard X series use new generation "Z screw" compression mechanism to achieve up to 10% volume up from previous models. Mounting Top Runner high efficiency motor and adopting new quick response system, now Zgaiard X series become more energy-saving to save the earth and customer cost together. In addition to that, Zgaiard X become tougher(ambient temperature 50°C), and cleverer (new 7.0inch touch panel) !

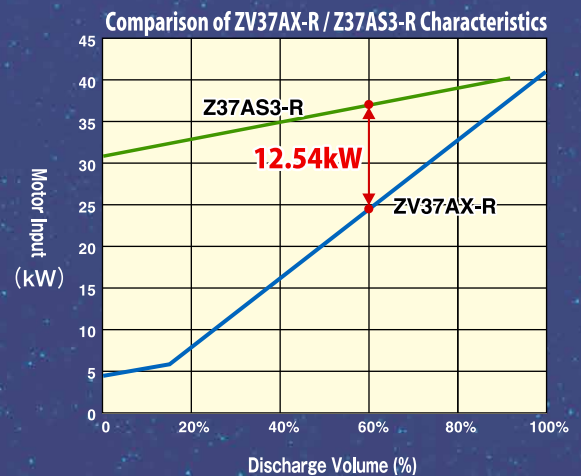

Discharge Air Volume Up

As a machine tools manufacturer, ZgaiardX series achieve high performance air end.



Both Inverter Type / Basic Type New Features

Large Air Volume

New manufacturing technology and analysis enables high performance air end. Up to 10% bigger air volume than previous models.

Top Runner Motor

Zgaiard series use Top Runner high efficient motor. (Top Runner is Japanese high efficient motor regulation.)



Tough Against Global Warming

Machine will not stop even ambient temperature become 50°C. When discharge temperature become 95°C, compressor become cooling mode to maximize cooling function.

(※40°C and higher ambient temperature may shorten electric parts life time.)

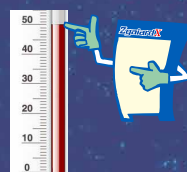

Easier Maintenance

Oil flow piping design become modularized so that maintenance become easy and need fewer parts.





■ Inverter Type New Features

○ Quick Response System

- New quick response re-start system is added to AUCS(Auto Unloader Control System).
- ZgaiardX can now respond quickly to customer air demand fluctuations.

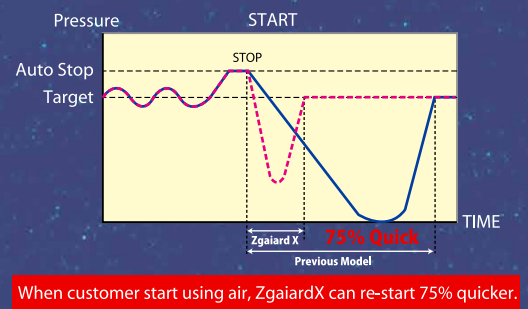
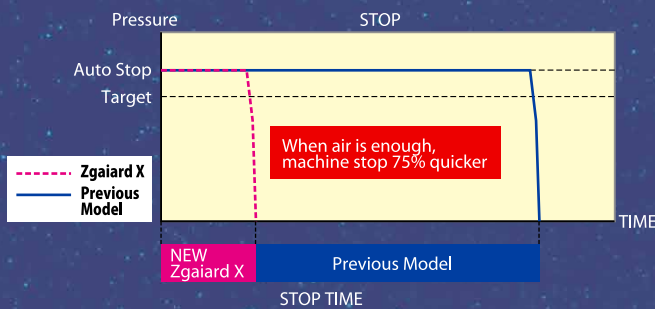

○ New 7.0inch Touch Panel IT Display

- Multi-function, Easy-operation LCD Touch Panel Display.
Data Downloading Function (Running data is downloaded to USB memory.)
Weekly Schedule Running Function (Setting by day and time.)
Sudden Power Failure Re-start Function (up to 20seconds)
2 Machines (Main unit/Back-up unit) Switching Operation(by connecting to other machine by wiring)
- Over-heat Pre-alarm Function
When ambient temperature become 45°C, machine shows Pre-alarm.
Ambient temperature sensor enables more efficient machine operation.
- Compressor Remote Monitoring Application Function.
PC monitoring software Z-mate(option) is also available.

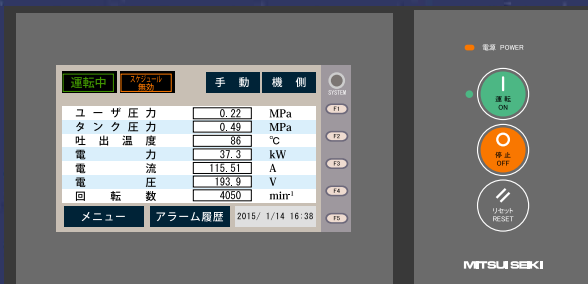
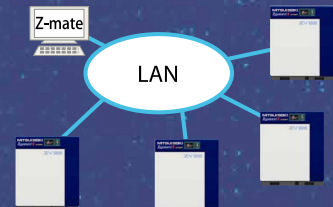

- Sudden Power Failure Re-start (up to 20 seconds)
- Weekly Schedule Running Function
- 2 Machines Switching Operation Function
- Z-mate PC Monitoring Software(option).
- Data Sampling Function.(Discharge temperature, Ambient temperature, Pressure, kW, Voltage, Ampere, Tank pressure and Rotation speed.)
- Data can be downloaded to USB memory and viewed from PC.

2 Machines Switching Operation Function

Main unit/Back-up unit auto exchange. It can be used with weekly operation function.

ZgaiardX series Inverter Compressor 55 / 75kW

MITSUBISHI SEIKI OIL INJECTION TYPE SCREW COMPRESSOR SERIES

Zgaiard X series 55kW and 75kW debut!



New design screw rotor and high efficient permanent magnetic motor (IPM) achieved ultimate energy-saving efficient air compressor ever. Layout of components are totally re-designed and become surprisingly compact. When compared to previous model, many environmental aspects are increased; low noise, fewer parts, needs less oil and ambient temperature up to 50°C. New Zgaiard X series compressor will provide future innovative solution to customers.

High Discharge Volume

- High precision manufacturing air end.
- New design screw rotor to better compression efficiency.
- 7% air volume up than previous model(55kW)
- Lubricate oil injection process is optimized.

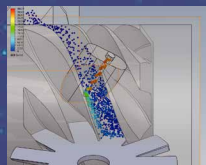

Compact Machine Space

- Re-designed layout of components to more compact.
- Tank size become smaller, to be realized to reduce 22L oil volume than previous.
- Number of parts 20% reduced.
- Most Compact Design Compressor.

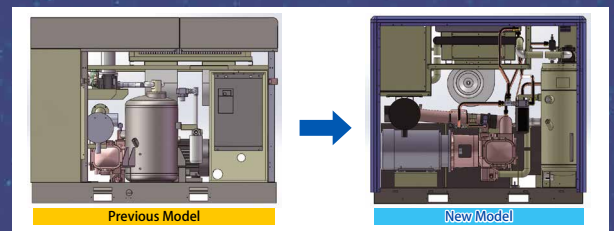

7.0inch Touch Panel Wide Display

New Features

Eco Status Indicator (Simplified Display)



Output Signal Setting

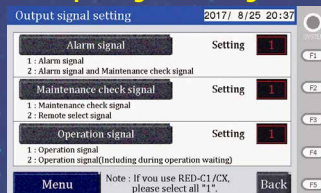

Data Sampling Interval Setting



Pressure Can Set Two Patterns



ZgaiardX series

Inverter Compressor
Basic type

7.5~15kW

MITSUI SEIKI OIL INJECTION TYPE SCREW COMPRESSOR SERIES

*Compact
but powerful basic type*



■ Delivery air volume comparison

ZV08AX-R	ZV11AX-R	ZV15AX-R
Z085/6AX-R	Z115/6AX-R	Z155/6AX-R
1.21m³/min	1.86m³/min	2.64m³/min

- High precision manufacturing air end.
- New design screw rotor to better compression efficiency.
- Lubricate oil injection process is optimized.

■ Simple structure

- Motor direct connection drive with no power loss
- Removal of consumable parts through one-touch operation
- Most appropriate direct drive with Z screw

■ Environmental measure

- Adopted the SUS plate type dryer heat exchanger. Improved anti-corrosion.
- Dryer heat exchanger capacity up.

■ Delivery air volume comparison 15kW unit:

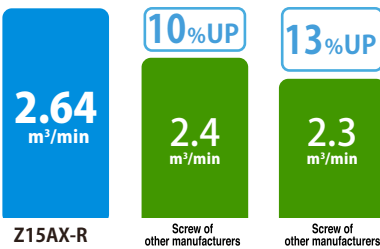

ZgaiardX series

Basic type 55 / 75kW

MITSUI SEIKI OIL INJECTION TYPE SCREW COMPRESSOR SERIES

■ Compact Machine Space

- Re-designed layout of components to more compact.
- Tank size become smaller, to be realized to reduce 22L oil volume than previous.



■ Tough Against Global Warming

- Machine will not stop even ambient temperature become 50°C.



Inverter Compressor *Zgalard series* 100/150kW

MITSUBI SEIKI OIL INJECTION TYPE SCREW COMPRESSOR SERIES

Only Z screw can realize high efficiency equal to single or double stage compressor.

Energy Saving



The effectiveness can be maximized with Basic machine operates at full load and Inverter machine to absorb load fluctuation.

150kW

Reduced power amounts

33% Reduced

Annual power consumption

4.5 million yen/year Reduced

Annual CO₂

176t/CO₂ Reduced

(Air Discharge Volume of 60%) (150 kW, 0.7 MPa)

- Air Discharge Volume: 60%
- Power Charges: 15 yen/kWh
- Running Time: 6,000 h/year

150kW Air Discharge Volume: 60%

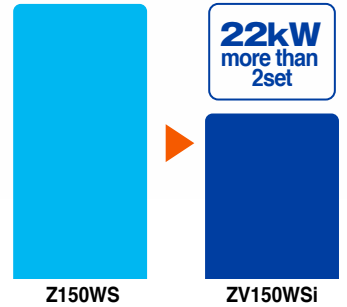

Combination of Fixed Speed Machine and Inverter Machine

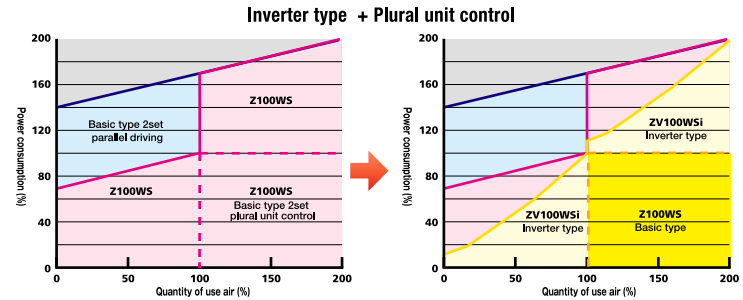

Select the Optional System to Suit Your Needs

Monitor operating status in real time **Remote Monitoring System** **Z-mate**

From a computer, you can monitor the operating status of up to 10 air compressors connected over a in-house LAN system or other Ethernet connection. You can also save monitoring data and operating air compressors by remote control.

※ Only air compressor models with a built-in LCD monitor IT touch panel can be connected.

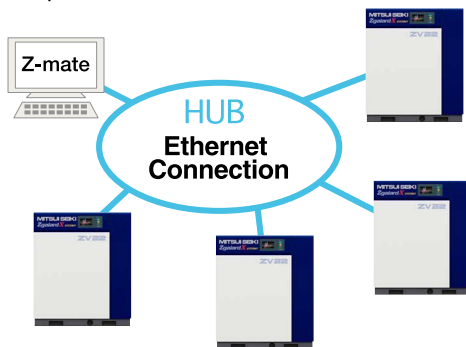

Ethernet is a registered trademark of Xerox Corp.

Unprecedented compression mechanism implemented by long experience

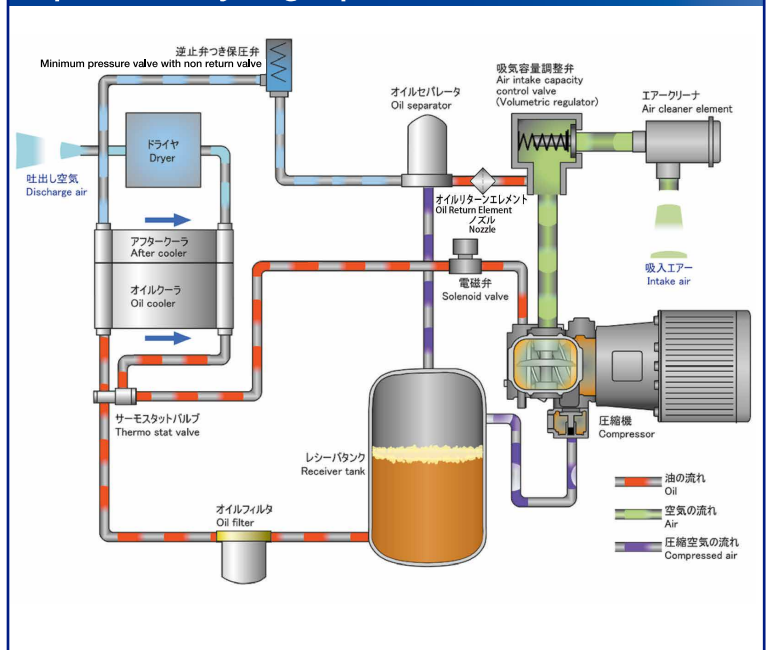

Scroll air compressor to deal with environment and energy saving.

Escal's Power

High efficient power created by gentle and smooth revolution. Overwhelming delivery airflow volume maximum in the class is presented by sealing effect of oil membrane continually created in compression chamber.

Delivery air volume comparison 3.7 kW unit:

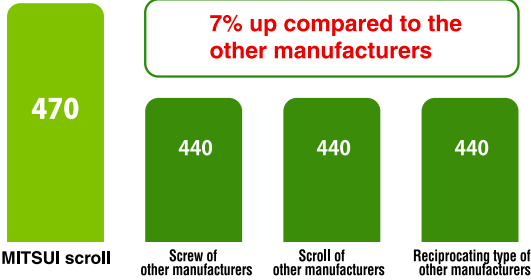

Escal's Energy-saving

- Auto start/stop system combined with the high energy saving unloader system. Applicable to deal with the intermittent and continuous operation. Also applicable to set the continuous unloader system depending on the air application condition.
- Auto dry timer as standard equipment to prevent the occurrence of drain.
- Applicable to set the advance operation of the Dryer.



Escal's Quiet

Non-contact and low noise, low vibration scroll rotation without tip sealing is achieved by the high precision machining center of MITSUI SEIKI.

Compression process of the Scroll compressor

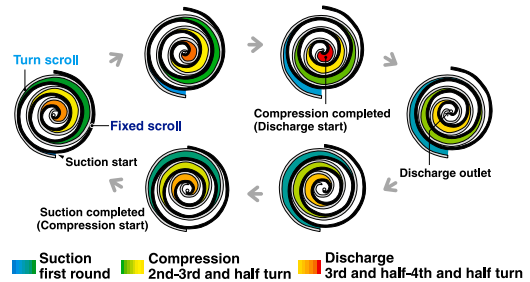

Flexible Wide Range Large Load Machine
Scrum type with 75kW Fixed Speed and 75kW inverter Combination.

Machine is equipped with two air ends.

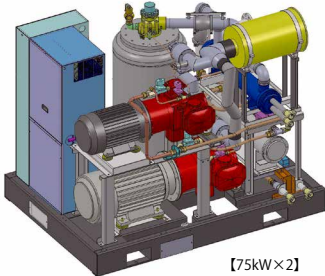

[75kW×2]

省工本特性比較

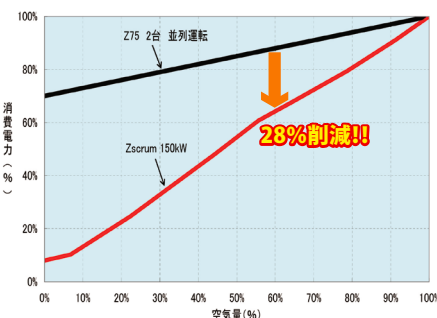

Energy saving

- Largest Air Volume.
- Wide Range Load Control.
- Machine has Super Premium High Efficient Motor.
- Machine has also IPM Motor and Inverter.

Energy Saving: 28% Reduction
from 2 sets of 75kW fixed speed machine
(Air Discharge Volume of 60%)

Reduction of machine and maintenance space

- More compact than plural unit mid-size machine.
- Parts is modularized.
Maintenance need fewer parts.

Machine Space: 20% Reduction
from 2 sets of 75kW machine

Risk hedge

- Even one air end is broken, avoiding to stop all air supply for the factory.



Inverter+Basic Scrum 150kW

model	ZV1505WSD	ZV1506WSD
Delivered air pressure (MPa)	0.7 (0.53~0.70)	
Free air delivery (m ³ /min)	26	
Intake air pressure & temperature	Atmospheric pressure (2~40°C)	
Main motor power (kW)	150 (75×2)	
Power source voltage (50/60Hz,V)	200	200/220
Motor type	M1	Totally enclosed fan cooled IPM motor
	M2	3-phase squirrel cage, 2P totally-enclosed external fan (IE3 motor)
Starter	M1	Inverter starter
	M2	3-contactor, star delta start
Drive system	Direct coupled motor	
Cooling system	Water cooled	
Fan motor power (kW)	0.15	0.22
Oil fill ration (L)	100	
Discharge pipe diameter (R)	JIS 10K 3B (80A) Flange	
Dimension	Width (Dryer less) (mm)	(2300)
	Length (mm)	1650
	Height (mm)	1900
Total mass (Dry state) (kg)	3100	
Noise level (dB (A))	69	

○ Noise values measured in noiseless environment at distance of 1.5meters from front, at height of 1m, with load of 100% (at 0.7MPa)
 ◎ Cooling water volume (water temp. 32): 150kW: 210L/min

Regulate Eco Drive Controller

Attempts energy saving by driving minimum required numbers of plural air compressors according to air consumption (Maximum controlled unit: eight unit.). Digital pressure indication enables driving of the minimum number in precise pressure range. Further energy saving is materialized by combination of inverter machine and standard un-loader machine or plural unit control of inverter machine only.



Plural units control examples

ZV&Z Control ZV 75kW×1set + Z 75kW×3set Free air delivery 52m³/min

In case of 1 set of inverter machine

Inverter machine runs first and stops last. Ideal driving is enabled as the standard machine runs with full load whereas the inverter machine runs by controlled number of the rotation depending on load fluctuation.

In case of plural number of inverter machines

Double loop driving with rotation function of inverter machine is viable.

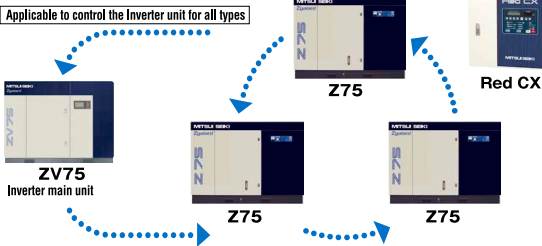

Simulation of Air usage conditions: Max46m³/min ↔ Min20m³/min

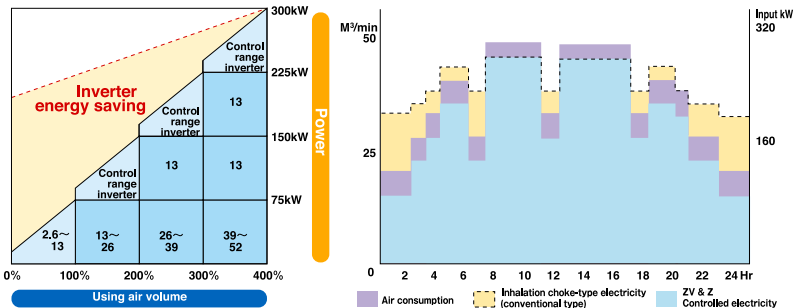

Function of plural unit Control System

Averaging operating time

Additional function



Pressure sensor detects air pressure and starts / stops compressor. Red CX chooses which compressor to start / stop in order to average the operating time. Having operated for a certain time, running compressor averages the operating time in rotating.

Start and stop in fixed order

New function



If you set starting order, it starts and stops in that rotation.

Averaging the operating time of inverter machine

Additional function



If you use both standard machine & inverter machine Standard machine runs in the way averages the operating time. Inverter machine rotates in optional time.

Alternate operation

New function



You can operate main machine and subordinate machine alternately. When the main machine has run for a certain time, subordinate one starts to run in exchange so that operating time is averaged.

Permanent fixed operation

New function

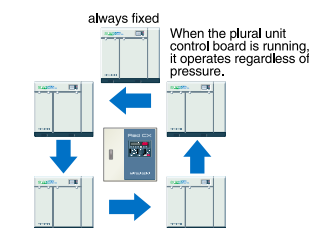

You can set which compressor to run all the time. The fixed compressor starts to operate first and continue running. The other compressors can be running in all operation pattern.

Turn back control

New function



If sizes of machines are different Set starting order. Compressors start to run in that order stop reversely.

2 pattern of pressure setting by weekly timer

New function

ex.) You can set different pressure day and night / weekdays and the weekend.

Receiver tank

Material SS400-SM490A

Attachment safety valve, pressure gauge, drain valve

Color Munsell 7.5Y7/1

Certification the second sort pressure vessel certificate

Applicable compressor	Tank capacity (L)
3.7~5.5kW	200
7.5~15kW	200~500
22kW	500~700
37kW	700~1000
55kW	1000~2000
75kW	1500~3000

※Further, for general application, it is recommended to install the air tank of delivery air capacity 10~20%.

※Please ask us when you choose vessel's volume in terms of pressure, air consumption or holding time.



Model	Tank capacity (L)	Maximum allowable pressure (MPa)	Mass (kg)	Outer diameter D (φmm)	Height H (mm)	Air outlet / inlet connection diameter	
						Socket	Flange
MTA-02	201	1.00	115	462	1660	Rc1	
MTA-03	298	1.00	150	512	1921	Rc1-1/2	
MTA-05	498	1.00	270	666	1978	Rc1-1/2	
MTA-07	698	1.00	330	766	2072		50A
MTA-10	991	1.00	440	868	2253		50A

※About 100, 400, 1500~6000L vessels, please ask us.

※If you use oil-free air, we recommend having inside epoxy-coated(option).

※There is no duty to submit registration of vessel setting, please observe safety regulation of boilers and pressure vessels based on Industrial Safety and Health Act.

※Designs of product may be changed without prior notice. Ask us about detailed information.

Clean air system

Put a combination of various filters in the piping in proportion to the required air cleanliness to obtain much more clean compressed air.



use	result
Line filter Air tool, Air motor, Air press, general painting, spray lubrication	Dry air nominal filtering rating : 1~5μm In such a case that inclusion of a certain oil or dust after waterelimination was allowed.
Line filter + mist filter For instrumentation, static painting, dry, electronic parts	Dry and oil eliminated air nominal filtering rating : 0.1~0.01μm In such a case that the air eliminated almost all the water, oil and dust was required.
Line filter + mist filter + activated carbon filter For medicament, food, brewing, ozone generator, scientific analysis equipment and caisson shielding	Dry, oil and smell eliminated air nominal filtering rating : 0.003~0.01μm In such a case that the air eliminated almost all the water, oil, dust and smell was required.

Customizing specification option

Medium pressure (1.37MPa) specification Delivery pressure is set to 1.37MPa. Most appropriate for the use of Laser unit and the like (applicable to Z15, 22kW)

Low voltage volume increase specification Discharge air volume shall be lowered to increase the delivery air volume (applicable to the Increasing type ZV 22kW~75kW)

380V-400V different voltage Applicable to change the main circuit voltage. Electricity 200V shall be self supplied to the Operation circuit and Dryer power supply through the Down transformer.

Cold region specification Countermeasure shall be supplied for the cold region to operate the unit in a safe condition. The unit shall automatically keep the heat when the atmosphere temperature dropped to prevent the Dryer and Drain from freezing up.

Outdoor specification Waterproof package applicable to install outdoor to confront the rain flooding.

Water cooling type Applicable to replace the cooling unit with a water cooling type when the application of the air cooling type was difficult under environmental condition such as not possible to ensure the ventilation (applicable to 22kW and 37kW)

ASME specification tank Applicable to change the tank built-in the compressor to ASME code specification for delivery abroad (except for USA).

* Some specifications are not applicable depending on the unit type. Please contact us for details.

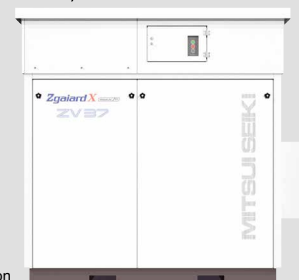

Outdoor specification

Zgaiard / Zgaiard X

• Inverter 7.5kW~75kW

model	Zgaiard X ZV08AX-R	Zgaiard X ZV11AX-R	Zgaiard X ZV15AX-R	Zgaiard X ZV22AX-R	Zgaiard X ZV37AX-R	Zgaiard X ZV55AX-R	Zgaiard X ZV75AX-R	Zgaiard X ZV55WX-R	Zgaiard X ZV75WX-R	
Delivered air pressure (MPa)	0.7 [0.60~0.93]		0.7 [0.54~0.93]		0.7 [0.53~0.93] (0.5) ※					
Free air delivery (m³/min)	1.21	1.86	2.64	4.2 (4.5) ※	7.0 (7.4) ※	10.2 (11.5) ※	13.4 (14.7) ※	10.2/11.5 ※	13.4/14.7 ※	
Intake air pressure & temperature	Atmospheric pressure (2~40°C)									
Main motor power (kW)	7.5	11	15	22	37	55	75	55	75	
Power source voltage (50/60Hz,V)	200/200-220									
Motor type	3-phase squirrel cage, 2P totally-enclosed external fan (IE3 motor)			Totally enclosed fan cooled IPM motor						
Starter	Inverter starter									
Drive system	Direct coupled motor									
Cooling system	Air cooled							Water Cooled		
Fan motor power (kW)	0.4 (Inverter control)		0.9 (Inverter control)	0.75 (Inverter control)	2.2 (Inverter control)	1.5 (Inverter control)	2.2 (Inverter control)	0.08/0.12	0.15/0.22	
Oil fill ration (L)	7		9	15	20	38				
Dryer	Air dew point at outlet (°C)									
	10 (under applied pressure) *									
	Electricity consumption (kW)									
Used refrigeration	R-407C			R-410A						
Refrigeration amount (g)	240	260	300	650	1050	1050	1450	1050	1450	
Discharge pipe diameter (R)	3/4		1		1 1/2		2			
Dimension	Width (Dryer less) (mm)		905		1050		1280 (1160)		1750 (1550)	
	Length (mm)		705		750		2008			
	Height (mm)		1400		1490		1550		1750	
Total mass (Dry state) (kg)	420	480	550	590	830	1350	1500	1350	1750	
Noise level (dB (A))	52	53	54	54	58	64	66	63	65	

Cautions: Dryer of low pressure specifications (option) shall be separate type. Please contact us for dryer dimensions and mass.

※: Values in () are the free air delivery for 0.5MPa specification (option)

* Values with ambient temperature of 30; and rated discharge pressure.

© Noise values measured in noiseless environment at distance of 1.5meters from front, at height of 1m, with load of 100% (at 0.7MPa)

© Specifications for 22 to 37kW water-cooled unit available on request (option)

© Cooling water volume (water temp. 32); 55kW: 80L/min; 75kW: 110L/min

Notation

Z V - 1 5 A S 5 - R
 ① ZV Series
 ② 15kW ③ Air-cooling
 ④ Type name ⑤ Built-in air dryer

Z V - 2 2 A X - R
 ① ZV Series
 ② 22kW ③ Air-cooling
 ④ Type name ⑤ Built-in air dryer

Zgaiard ZV series

• Inverter 150kW

model	ZV150AS2i	ZV150WS2i
Delivered air pressure (MPa)	0.7 [0.54~0.93]	
Free air delivery (m³/min)	26.0	
Intake air pressure & temperature	Atmospheric pressure (2~40°C)	
Main motor power (kW)	150	
Power source voltage (50/60Hz,V)	400	
Motor type	Totally enclosed fan cooled IPM motor	
Starter	Inverter starter	
Drive system	Direct coupled motor	
Cooling system	Air cooled	Water cooled
Fan motor power (kW)	5.5	0.15/0.22
Oil fill ration (L)	100	
Discharge pipe diameter (R)	JIS 10K 3B (80A) Flange	
Dimension	Width (Dryer less) (mm)	
	(3600)	(2650)
	Length (mm)	
1350		
Height (mm)		
2155		
1750		
Total mass (Dry state) (kg)	3400	3200
Noise level (dB (A))	78	74

© Noise values measured in noiseless environment at distance of 1.5meters from front, at height of 1m, with load of 100% (at 0.7MPa)

© Cooling water volume (water temp. 32); 150kW: 200L/min

ESCAL series

• Scroll 3.7kW / 5.5kW

model	ESCAL 45A2-R	ESCAL 46A2-R	ESCAL 65A2-R	ESCAL 66A2-R
Delivered air pressure (MPa)	0.83			
Free air delivery (m³/min)	470		730	
Intake air pressure & temperature	Atmospheric pressure (2~40°C)			
Capacity control method	Select the auto start/stop or unloader type			
Main motor power (kW)	3.7		5.5	
Power source voltage (50/60Hz,V)	200/200-220			
Motor type	3-phase squirrel cage 4P totally enclosed external fan (IE3 motor)			
Starter	Direct ON start			
Drive system	V belt drive			
Cooling system	Air cooled			
Oil fill ration (L)	3.5		4.5	
Dryer	Air dew point at outlet (°C)			
	10 (under applied pressure) *			
	Electricity consumption (kW)			
0.296	0.260-0.236	0.296	0.260-0.236	
Used refrigeration	R-407C			
Refrigeration amount (g)	280			
Discharge pipe diameter (R)	1/2			
Dimension	Width (Dryer less) (mm)			
	785			
	Length (mm)			
505				
Height (mm)				
1140 (790)				
Total mass (Dry state) (kg)	240		260	
Noise level (dB (A))	49		52	

* Values with ambient temperature of 30; and rated discharge pressure.

© Noise values measured in noiseless environment at distance of 1.5meters from front, at height of 1m, with load of 100% (at 0.83MPa)

Notation

Z V - 5 5 W X - R
 ① ZV Series
 ② 55kW ③ Water-cooling
 ④ Type name ⑤ Built-in air dryer

ESCAL 4 5 A 2 - R
 ① ESCAL Series
 ② 4=3.7kW ③ 5=5.5kW
 ④ 5=50Hz ⑤ 6=60Hz
 ⑥ Air-cooling ⑦ Type name
 ⑧ Built-in air dryer

Zgaiard / Zgaiard X

•Basic 7.5kW~37kW

model	Zgaiard X Z085AX-R	Zgaiard X Z086AX-R	Zgaiard X Z115AX-R	Zgaiard X Z116AX-R	Zgaiard X Z155AX-R	Zgaiard X Z156AX-R	Zgaiard X Z225AX-R	Zgaiard X Z226AX-R	Zgaiard X Z375AX-R	Zgaiard X Z376AX-R
Delivered air pressure (MPa)	0.7									
Free air delivery (m ³ /min)	1.21		1.86		2.64		4.1		6.9	
Intake air pressure & temperature	Atmospheric pressure (2~40°C)									
Capacity control method	Power-saving AUCS Automatic start/stop selection									
Main motor power (kW)	7.5		11		15		22		37	
Power source voltage (50/60Hz,V)	200/200•220									
Motor type	3-phase squirrel cage, 2P totally-enclosed external fan (IE3 motor)									
Starter	Direct ON start					3-contactor, star delta start				
Drive system	Direct coupled motor									
Cooling system	Air cooled									
Fan motor power (kW)	0.4		0.9		0.75		2.2			
Oil fill ration (L)	7		9		15		20			
Air dew point at outlet (°C)	10 (under applied pressure) *									
Electricity consumption (kW)	0.352	0.408•0.432	0.360	0.440•0.460	0.528	0.612•0.640	1.1	1.3	1.4	1.7
Used refrigeration	R-407C					R-410A				
Refrigeration amount (g)	240		260		300		650		1050	
Discharge pipe diameter (R)	3/4		1		1		1 1/2			
Width (Dryer less) (mm)	905		1050		1280		1750 (1550)			
Length (mm)	705		750							
Height (mm)			1400		1490		1550			
Total mass (Dry state) (kg)	400		470		540		680		970	
Noise level (dB (A))	53		55		56		54		59	

* Values with ambient temperature of 30; and rated discharge pressure.

○ We have 0.83 / 0.88 / 0.93 MPa version (option). Please contact us for details.

○ Noise values measured in noiseless environment at distance of 1.5meters from front, at height of 1m, with load of 100% (at 0.7MPa)

○ Specifications for 22 to 37kW water-cooled unit available on request (option)

•Basic 55kW~75kW

model	Zgaiard X Z555AX-R	Zgaiard X Z556AX-R	Zgaiard X Z755AX-R	Zgaiard X Z756AX-R	Z555WS4-R	Z556WS4-R	Z755WS4-R	Z756WS4-R
Delivered air pressure (MPa)	0.7							
Free air delivery (m ³ /min)	10		13.2		9.5		13.0	
Intake air pressure & temperature	Atmospheric pressure (2~40°C)							
Capacity control method	Power-saving AUCS Automatic start/stop selection							
Main motor power (kW)	55		75		55		75	
Power source voltage (50/60Hz,V)	200/200•220							
Motor type	3-phase squirrel cage 2P totally-enclosed external fan (IE3 motor)							
Starter	3-contactor, star delta start							
Drive system	Direct coupled motor							
Cooling system	Air cooled				Water Cooled			
Fan motor power (kW)	3.7		0.08		0.12		0.08	
Oil fill ration (L)	38		60					
Air dew point at outlet (°C)	10 (under applied pressure) *							
Electricity consumption (kW)	1.72	2.13	2.3	2.8	1.9	2.4	2.4	2.8
Used refrigeration	R-410A							
Refrigeration amount (g)	1050		1450		1050		1300	
Discharge pipe diameter (R)	2							
Width (Dryer less) (mm)	2008		1990 (1550)		2240 (1800)			
Length (mm)	1183		1200					
Height (mm)	1750		1700					
Total mass (Dry state) (kg)	1600		1610		1700			
Noise level (dB (A))	66		69		65		66	

* Values with ambient temperature of 30; and rated discharge pressure.

○ We have 0.83 / 0.88 / 0.93 MPa version (option). Please contact us for details.

○ Noise values measured in noiseless environment at distance of 1.5meters from front, at height of 1m, with load of 100% (at 0.7MPa)

○ Cooling water volume (water temp. 32); 55kW: 80L/min; 75kW: 110L/min

•Basic 100kW~150kW

model	Z1505AS2	Z1506AS2	Z1505WS2	Z1506WS2
Delivered air pressure (MPa)	0.7			
Free air delivery (m ³ /min)	27.0	26.0	27.0	26.0
Intake air pressure & temperature	Atmospheric pressure (2~40°C)			
Capacity control method	Power-saving AUCS Automatic start/stop selection			
Main motor power (kW)	150		150	
Power source voltage (50/60Hz,V)	400	440	400	440
Motor type	3-phase squirrel cage 2P totally-enclosed external fan (IE3 motor)			
Starter	3-contactor, Star delta start		3-contactor, Star delta start	
Drive system	Direct coupled motor			
Cooling system	Air cooled		Water cooled	
Fan motor power (kW)	5.5		0.12	
Oil fill ration (L)	100		100	
Discharge pipe diameter (R)	JIS 10K 3B (80A) Flange			
Width (Dryer less) (mm)	3200		2860	
Length (mm)	1350		1350	
Height (mm)	2155		1750	
Total mass (Dry state) (kg)	3410		3050	
Noise level (dB (A))	78		74	

○ We have 0.83 / 0.88 MPa version (option). Please contact us for details.

○ Noise values measured in noiseless environment at distance of 1.5meters from front, at height of 1m, with load of 100% (at 0.7MPa)

○ Cooling water volume (water temp. 32); 150kW: 200L/min

⚠ Safety instructions

- Free air delivery is the volume of delivery air discharged when air pressure is applied to the intake (atmospheric pressure). (JIS B 8341)
- Do not use delivery air for respirator equipment whose discharge is inhaled directly.
- Maintain ventilation so that intake air temperature does not exceed 40;. Use the compressor indoors.
- Contact us for guaranteed values.
- Do not drain water discharge from the compressor directly into rain gutters. Follow any applicable wastewater regulations. Please contact your Mitsui Seiki sales representative if you have any questions or problems.

Compressor installation

Precautions for installation location

Some installation environments can damage the compressor or cause malfunctions. Please follow the precautions below in order to ensure the efficient, safe, and long-term use of your compressor.

Installation environment

- ▲ Avoid installing outdoors, in semi-outdoor locations, in locations exposed to rain, and the like.
- ▲ Avoid installing in locations exposed to dust or toxic gases.
- ▲ Install in a location with an ambient temperature between 2 and 40.
(We recommend the optional cold-weather specification if installing in temperatures of 2; and lower)

Location

- ▲ Install on a firm, level floor.
- ▲ Install in a spacious, well lit location enabling operation to be monitored easily.
- ▲ There should be no impediments to transporting the unit to/from the location or performing maintenance.

Electrical wiring

- ▲ All electrical wiring during installation must be done in accordance with technical standards. Electrical leaks, worn insulation, overcurrent, short circuits, open-phase driving, and defective protective equipment could cause sparks from the electrical wiring or electronic circuits.
- ▲ Install a non-fuse breaker on the main power line if the model so requires.
- ▲ Connect a ground cable to prevent electrical leaks.
- ▲ Never remove protective equipment or perform modifications that disables an electronic circuit's protective features.

Maintenance

- ▲ We recommend conducting maintenance and inspection ahead of the standard schedule in accordance with the installation environment and location.

Ventilation

- ▲ The compressor room must be ventilated. Install a ventilation fan, duct, or the like so that the ambient temperature does not exceed 40;. Failure to do so could cause the compressor to overheat, or damage the insulation of electrical components.

Installation space

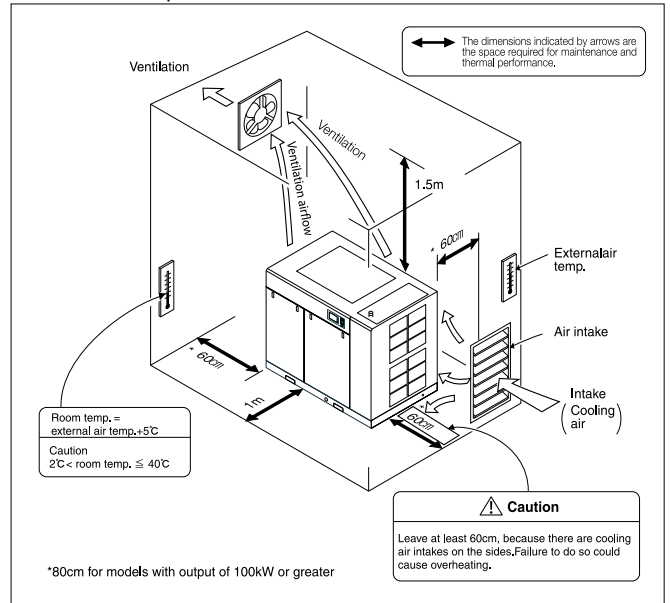

Installation Requirements Please consult with Mitsui Seiki or a designated service shop for details

Model	Non-fuse breaker		Power transformer Capacity (200/400V)	Secondary wiring cable Below 22kW less 10m, Over 37kW less 20m				Cooling tower For CT outlet temp. of 32°C
	200/220V	400/440V		200/220V	Grounding cable	400/440V	Grounding cable	
Z08AX-R	100AF-60AT	50AF-40AT	15KVA	8mm ² M5	5.5mm ² M5	3.5mm ² M4	5.5mm ² M4	—
Z11AX-R	100AF-100AT	50AF-50AT	20KVA	14mm ² M5	14mm ² M5	5.5mm ² M4	14mm ² M5	—
Z15AX-R	100AF-100AT	100AF-60AT	25KVA	22mm ² M8	14mm ² M5	14mm ² M5	14mm ² M5	—
Z22AX-R	225AF-200AT	100AF-100AT	35KVA	38mm ² M10	22mm ² M5	22mm ² M8	22mm ² M5	10t or more
Z37AX-R	※1 NV250-SEV,HEV NF250-SEV,HEV-225AT	NV250-SEV,HEV NF250-SEV,HEV-150AT	55KVA	100mm ² M10	22mm ² M5	38mm ² M8	22mm ² M5	10t or more
Z55AX-R	NV400-SEW,HEW NF400-SEW,HEW-400AT	225AF-225AT	75KVA	150mm ² M12	38mm ² M8	60mm ² M10	38mm ² M8	—
Z55WS4-R	NV400-SEW,HEW NF400-SEW,HEW-400AT	225AF-225AT	75KVA	150mm ² M12	38mm ² M8	60mm ² M10	38mm ² M8	15t or more
Z75AX-R	※2 NV400-SEW,HEW NF400-SEW,HEW-400AT	※1 NV250-SEV,HEV NF250-SEV,HEV-225AT	105KVA	200mm ² M12	38mm ² M8	100mm ² M10	38mm ² M8	—
Z75WS4-R	※2 NV400-SEW,HEW NF400-SEW,HEW-400AT	※1 NV250-SEV,HEV NF250-SEV,HEV-225AT	105KVA	200mm ² M12	38mm ² M8	100mm ² M10	38mm ² M8	20t or more
Z150AS2	—	NV400-SEW,HEW NF400-SEW,HEW-400AT	300KVA	—	—	250mm ² M12	60mm ² M8	—
Z150WS2	—	NV400-SEW,HEW NF400-SEW,HEW-400AT	300KVA	—	—	250mm ² M12	60mm ² M8	40t or more
ZV08AX-R	50AF-50AT	30AF-30AT	20KVA	5.5mm ² M6	5.5mm ² M6	2mm ² M6	2mm ² M6	—
ZV11AX-R	100AF-75AT	50AF-40AT	25KVA	8mm ² M6	8mm ² M6	3.5mm ² M6	3.5mm ² M6	—
ZV15AX-R	225AF-125AT	100AF-60AT	30KVA	22mm ² M8	14mm ² M8	8mm ² M6	8mm ² M6	—
ZV22AX-R	225AF-150AT	100AF-75AT	45KVA	38mm ² M8	22mm ² M8	14mm ² M6	14mm ² M6	10t or more
ZV37AX-R	225AF-225AT	225AF-125AT	65/75KVA	100mm ² M10	38mm ² M10	22mm ² M8	22mm ² M8	10t or more
ZV55AX-R	400AF-400AT	225AF-175AT	120KVA	100mm ² M12	38mm ² M12	60mm ² M8	22mm ² M8	—
ZV55WX-R	400AF-400AT	225AF-175AT	120KVA	100mm ² M12	38mm ² M12	60mm ² M8	22mm ² M8	15t or more
ZV75AX-R	400AF-400AT	225AF-200AT	125KVA	150mm ² M12	38mm ² M12	60mm ² M10	22mm ² M10	—
ZV75WX-R	400AF-400AT	225AF-200AT	125KVA	150mm ² M12	38mm ² M12	60mm ² M10	22mm ² M10	20t or more
ZV150AS2i	—	400AF-350AT	250KVA	—	—	100mm ² M12	38mm ² M12	—
ZV150WS2i	—	400AF-350AT	250KVA	—	—	100mm ² M12	38mm ² M12	40t or more
ESCAL4A2-R	30AF-30AT	30AF-20AT	7KVA	3.5mm ² M4	3.5mm ² M4	2mm ² M4	2mm ² M4	—
ESCAL6A2-R	50AF-50AT	30AF-30AT	10KVA	5.5mm ² M4	5.5mm ² M4	3.5mm ² M4	3.5mm ² M4	—
ZV150WSD	M1: Inverter	400AF-400AT	125KVA	150mm ² M12	38mm ² M12	—	—	40t or more
	M2: Basic	※2 NV400-SEW,HEW NF400-SEW,HEW-400AT	105KVA	200mm ² M12	38mm ² M12	—	—	

- ◎ Use a recommended SEW or HEW circuit breaker (made by Mitsubishi Electric Corporation). (If changing in same frame)
- ◎ If you use our designated NF series of non-fuse circuit breakers, use the NV series of designated leak-electricity circuit breakers (made by Mitsubishi Electric Corporation).
- ◎ Use power lines with a size of 55kW or less when the continuous maximum allowed temp. is 75; (e.g. NIV power lines). If the ambient temperature is 50; or less, it is assumed that the wiring separation will be 20m or less.
- ◎ Use power lines with a size of 75kW or more when the continuous maximum allowed temp. is 90; (e.g. LMFC power lines). If the ambient temperature is 50; or less, it is assumed that the wiring separation will be 20m or less.
- ※ Use tripping current adjustable size (x14) breaker

Ventilating the compressor room

Be very careful to ventilate the compressor room!

The compressor room must be ventilated. Install a ventilation fan, duct, or the like so that the ambient temperature does not exceed 40°C. Failure to do so could cause the compressor to overheat, or damage the insulation of electrical components.

Ventilation volume

Some installation environments can damage the compressor or cause malfunctions. Please follow the precautions below in order to ensure the efficient, safe, and long-term use of your compressor.

■ Installation environment

- ▲ Avoid installing outdoors, in semi-outdoor locations, in locations exposed to rain, and the like.
- ▲ Avoid installing in locations exposed to dust or toxic gases.
- ▲ Install in a location with an ambient temperature between 2 and 40; (We recommend the optional cold-weather specification if installing in temperatures of 2; and lower)

	Figure A. Overall ventilation	Duct ventilation	Install a ventilation fan in the duct
Ventilation method			
Precautions	<p>When whole compressor room ventilation without duct, please see below (A) figures. (These figures are when ΔT=5.)</p> <p>Ventilation fan should be located high near ceiling and air intake should be located low near compressor air inlet side.</p> <p>Air speed at air intake should be less than 2m/sec.</p> <p>Air intake=Ventilation(A)+ Free air delivery</p>	<p>Please calculate the duct size based on calculation of duct resistance from compressor exhaust volume; pressure loss should be below 29.4Pa (3mmAq).</p> <p>Ventilation duct should be removable from compressor so that maintenance work become easier.</p> <p>Please note noise from compressor might leak through ventilation duct.</p> <p>Exhaust fan is needed even ventilation duct is supplied. This is for dryer exhaust.</p> <p>Air intake=Ventilation(B)+ Heat exhaust (C) + Free air delivery</p>	<p>Please calculate the duct size based on calculation of duct resistance from compressor exhaust volume; pressure loss should be below 29.4Pa (3mmAq).</p> <p>Please note noise from compressor might leak through ventilation duct. Please surely keep 300~400mm space between exhaust duct inlet port and exhaust outlet port of the cooler.</p> <p>Please do not make a short space or directly connect to air compressor because it cause for the breakdown due to the over cooling.</p> <p>Air intake=Ventilation(D) + Free air delivery</p>

Ventilation volume Please consult with Mitsui Seiki or a designated service shop for details

Model	Heat output (MJ/h)		Room ventilation		Duct ventilation			Install a ventilation fan in the duct		
			Ventilation volume(m³/min)(A)		Ventilation volume(m³/min)(B)(50/60Hz)		Exhaust(m³/min)(C)(50/60Hz)			
	Compressor	Dryer	Dryer less	Built-in dryer type	Dryer less	Built-in dryer type	Compressor	Dryer less	Built-in dryer type	
Z08AX-R	30	6	82	99	4	21	24	33	50	
Z11AX-R	44	9	120	145	6	31	27	38	63	
Z15AX-R	60	13	164	200	8	44	49	67	103	
Z22AX-R	84	11	230	259	12	41	35	54	83	
Z37AX-R	140	18	387	437	20	69	75	110	159	
Z55AX-R	218	25	602	669	31	98	172/204	237/275	304/342	
Z55WS4-R	40	28	109	185	—	—	—	—	—	
Z75AX-R	297	33	821	911	42	131	198/191	279/270	369/360	
Z75WS4-R	54	33	149	240	—	—	—	—	—	
Z150AS2	540	—	1500	—	75	—	400/430	—	—	
Z150WS2	108	—	300	—	—	—	—	—	—	
ZV08AX-R	30	6	82	99	4	21	24	33	50	
ZV11AX-R	44	9	120	145	6	31	27	38	63	
ZV15AX-R	60	13	164	200	8	44	49	67	103	
ZV22AX-R	85	11	236	265	12	42	35	54	84	
ZV37AX-R	142	18	392	442	20	70	75	110	160	
ZV55AX-R	212	25	585	652	30	97	165	210	277	
ZV55WX-R	43	25	117	184	—	—	—	—	—	
ZV75AX-R	289	33	798	887	40	130	205	286	376	
ZV75WX-R	58	33	159	249	—	—	—	—	—	
ZV150AS2i	540	—	1500	—	75	—	400	—	—	
ZV150WS2i	108	—	300	—	—	—	—	—	—	
ESCAL4A2-R	14	3	39	44	2	8	15	20	28	
ESCAL6A2-R	20	3	55	62	3	11	19	26	34	
ZV150WSD	108	—	300	—	—	—	—	—	—	

■ Calculating ventilation requirement

$$Q = \frac{n \times H \times 1000}{1.2 \times \Delta T \times 60}$$

Q: Required ventilation volume (m³/min)

H: Heat output per unit (MJ/h)

n: Number of units△

T: Tolerated temperature rise (t1-t0)

(t1: tolerated indoor temp. (°C); t0: outside tem. (°C)) T is generally calculated as 5°C.

Piping

- Do not connect pipes with union joints or flange joints, so that they do not impede overhauls and the like.
- Make sure that the diameter of the main pipe is at least as large as the discharge outlet, in order to minimize the drop HV pressure. Install an approximately 1/100 slope to enable draining from the piping.
- Use a pipe diameter with enough leeway to reduce resistance, in accordance with the installed length of the piping.
- Install stop valves on the compressor discharge outlet, on both the user side and discharge side, in order to facilitate maintenance.
- Install air tanks, filters, and the like as needed, in accordance with the plant's air usage.
- See the installation manual for further details.

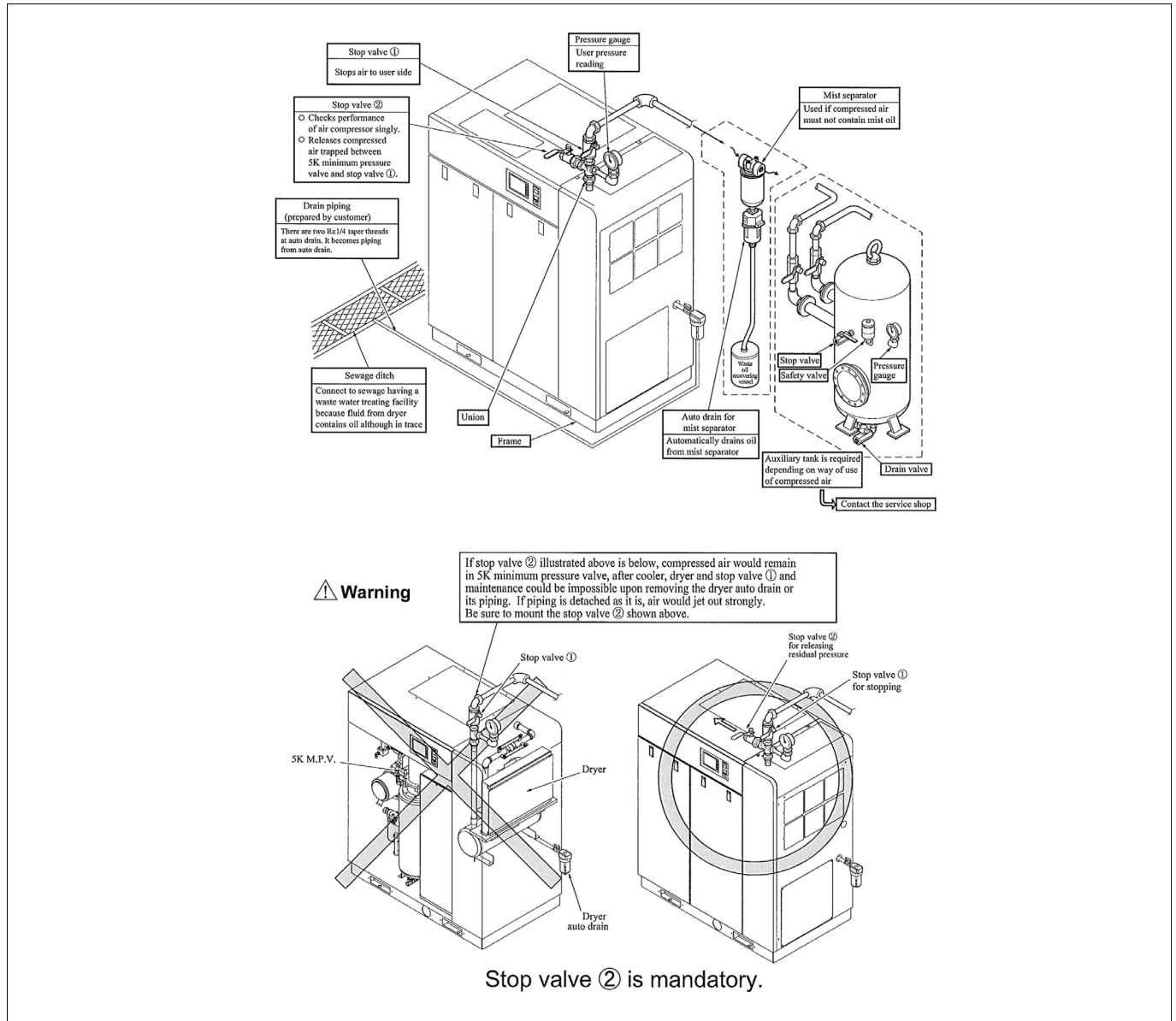

Pure oil

MITSUI genuine Compressor oil is lubrication oil developed for the Z screw. It is made up to fully perform its function and survive the long time operation. Please care to use the MITSUI genuine oil for the MITSUI products. Also pay attention not to use it mixed with another type oil.



Energy saving diagnosis

Attempts energy reduction of total facilities by a realistic implementation plan in view of general standpoint. Proposing a plan in view of "contribution to earth environment" in a middle term viewpoint and switching to clean energy.



Maintenance

[Oil type]

- Check the oil level of the Compressor every day.
- Adjust the amount of the drain (water) from the oil chamber in proportion to the load condition.
- Life cycle of the compressor oil is approximately 6,000 hours (for genuine oil Z-6000 compressor oil)
Replace the oil immediately after passed the life cycle.
Sooner replacement, if necessary as the dirt condition even not attained 6,000 hours, would help maintain good condition.

- Life cycle of the oil separator element is approximately 6,000 hours. Replace the oil separator element immediately after passed the life cycle.
- Life cycle of the oil filter is approximately 6,000 hours. Replace the oil filter immediately after passed the life cycle.
(Replacement period for the compressor oil, oil separator and oil filter shall become sooner according to the application circumstance).
- If a dust filter is blocking, it cause trouble. Clean filters regularly.
- Replace the Air cleaner element if the Monitor lamp lights up.
- Use Mitsui Seiki dedicated parts for maintenance part certainly.
- Execute other maintenance work based on Instruction Manual.

Have maintenance performed by a Mitsui Seiki Kogyo-certified technician (a service shop designated by Mitsui Seiki Kogyo).

Industrial Health and Safety Law "Ordinance on Safety of Boilers and Pressure Vessels"

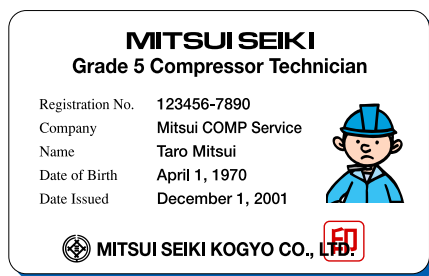

Mitsui Seiki Kogyo Technician Certificate

We distribute guides for safely installing and maintaining your compressor (published by the Japan Society of Industrial Machinery Manufacturers). Please read them together with your operation manual.

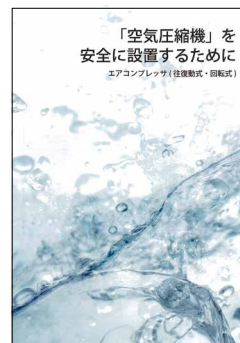

"Safe air compressor installation"



"Maintenance tips for safe, energy-efficient use of air compressors"

Laws and regulations relating to compressors

Industrial Health and Safety Law "Ordinance on Safety of Boilers and Pressure Vessels"

[Overview]

- Vessels with maximum pressure of 0.2MPa or higher, with capacity of 40L or higher
- Vessels with maximum pressure of 0.2MPa or higher, with internal diameter of 200mm or more, and length of 1,000mm or more

[Documents to submit]

- Second-class Pressure Vessel Description Handling Instructions
- Second-class Pressure Vessel Description (Original)
- ◎ Note: It is not necessary to submit these document, but keep them in a secure place, because they are important.

[Installation and use]

- Pressure vessels cannot be modified
- Perform self inspections at least once a year, and keep a record
- Adjust pressure delivered by safety valve
- Use a pressure gage with a maximum meter reading of 1.5 to 3 times the maximum pressure used, with a display that makes it easy to check the maximum pressure used.

Basic Environment Law "Noise Abatement Act/Vibration Control Law"

[Overview]

- Applies to compressors with rated drive output of 7.5kW or more. Check with the Pollution Section of your municipal office, because the regulation values differ by prefecture.

[Documents to submit]

- At least 30days before installing the compressor, you must submit a notice of start or change of construction to your prefectural government via the Pollution Section of your municipal government.

[Installation and use]

- The noise and vibration at the boundary of the plant grounds must be within the regulated levels.

"Law Concerning the Recovery and Destruction of Fluorocarbons" (Japanese Law)

The users of Classified Product(Commercial Refrigeration and A/C with CFC, HCFC and HFC) are required to conducted below three items.

- ① Products must be installed at adequate location.
 - ② Periodical check (once per 3month) by user and recording the result.
 - ③ When leakage was found, user have the responsibility of repairing the products . Re-filling of refrigerant without repair is prohibited.
- In case of bigger size refrigerate products.
In case of products with refrigerator capacity of bigger than 7.5kW, annual inspection by engineer with enough experience and knowledge (such as manufacturer and refrigerator maintenance engineer) is required by law.

Laws and regulations relating to the environment and energy conservation

Energy conservation laws (Energy Conservation Act)

Enacted April 1, 2006 (revision)

- Purpose
Reduce average annual energy per unit of production by at least 1%.
- Key points of revision
Improve energy efficiency measures of factories and offices obligated to conserve energy through the central management of heating and electricity.

Global warming laws (Law for the Promotion of Measures to Deal with Global Warming)

Enacted April 1, 2006 (revision)

- Kyoto Protocol Target Achievement PlanThe target is to reduce CO₂ emissions from industry by 8.6% from 1990 levels by the year 2010.
- Key points of revisionA system for calculating, reporting, and publishing greenhouse gases was introduced.

MITSUI SEIKI

<http://www.mitsuseiki.co.jp>



JQA-0904



JQA-EM2883



Home office plant



MITSUI SEIKI KOGYO CO., LTD.

6-13 Hachiman, Kawajima-Machi, Hiki-Gun,
Saitama, 350-0193, JAPAN
Phone +81-49-297-8711 Fax +81-49-297-5377

MITSUI SEIKI (THAILAND) CO.,LTD.

204/956 City Park Moo1, Soi Emthai, Teparak (k.m.22),
T. Bangsaothong, A. Bangsaothong, Samutprakarn, 10540, THAILAND
Phone +66 (0) 2-313-1881 Fax +66 (0) 2-313-1883

MITSUI SEIKI (SHANGHAI) SERVICE CO.,LTD.

No28, Minyi Rd. Xinqiao, Songjiang, Shanghai, 201612, CHINA
Phone +86 (0) 21-5768-7460 Fax +86 (0) 21-5768-6891

Contact information
Trusted Mitsui Seiki distributors